



GLX-RSS-2-100

GLX-RSS-2-300

Radar Speed Sensor User Manual

Revision History

Version	Date	Author	Approved by
1.0	2011-07-22	Tomislav Grubesa	Niksa Orlic



Starting Point

Thank you for purchasing Geolux GLX-RSS-2 radar sensor! We have put together the experience of our engineers, the domain knowledge of our customers, the enthusiasm of our team, and the manufacturing excellence to deliver this product to you.

You may freely rely on our field-proven technology for collecting vehicle speed data. The use of advanced signal processing algorithms ensures that Geolux Radar Speed Sensor can be used in any vehicle detection / vehicle speed measurement / road utilization measurement application.

Although we are certain that you are more than capable of connecting the Radar Speed Sensor to your system using a serial cable, we have created this User Manual to assist you in setting up and using Geolux Radar Speed Sensor device.

Should there be any questions left unanswered, please feel free to contact us directly:

Geolux d.o.o.
Ljudevita Gaja 62
10430 Samobor
Croatia

E-mail: geolux@geolux.hr

1. Introduction

Geolux Radar Speed Sensor devices are used to detect distant moving objects and measure the speed of detected objects (targets). This functionality is achieved by transmitting an electromagnetic wave in 24 GHz frequency range (K-band), and measuring the frequency shift of the reflected electromagnetic wave. The frequency shift is caused by the Doppler effect of the moving target on the electromagnetic wave. As the relative speed between the radar sensor and the target increases, the detected frequency shift also increases, thus enabling the radar sensor to precisely determine the target speed.

Two different models are made available by Geolux: GLX-RSS-2-100 and GLX-RSS-2-300. The only difference between these models is the transmission power of the radar antenna. GLX-RSS-2-100 model is a low-power device with effective target detection range of up to 250 meters (800 ft); GLX-RSS-2-300 model uses a high power transmitter to yield effective target detection range of up to 500 meters (1600 ft).

The radar sensor is able to detect moving objects (targets) traveling at speeds ranging from 5 km/h (3 mph) to 336 km/h (209 mph). Detected targets are tracked by the radar sensor, and the current speed, detection level and direction are reported over the serial (RS-232 or RS-485) interface or over the CAN 2.0B interface. The radar sensor is able to track multiple approaching and receding targets at the same time, which makes this radar sensor an excellent choice for multi-lane traffic monitoring.

2. Electrical Characteristics

The electrical characteristics of the Geolux Radar Sensor are given in the Table 1.

Table 1. Electrical characteristics

Parameter	MIN	TYP	MAX	Unit
Communication interface:				
RS-232 interface speed	1200		115200	bps
RS-485 interface speed	1200		115200	bps
CAN interface speed	125	500	1000	kbps
Radar Sensor				
Frequency		24.125		GHz
Radiated power (EIRP) GLX-RSS-2-100	16	18	20	dBm
Radiated power (EIRP) GLX-RSS-2-300	25	27	29	dBm
Sensitivity	-108	-110	-112	dBm
Beam-width (3dB) – Azimuth		12		°
Beam-width (3dB) – Elevation		24		°
Power supply voltage	9,0	12,0	27,0	V
Power dissipation		900	1350	mW
Operational temperature range	-40		+85	°C

3. Connector Pin-Out

The Radar Speed Sensor uses robust IP66 circular M12 connector with 12 positions and the mating cable is also delivered with Radar Speed Sensor. The connector and cable details are shown on Picture 1. The Table 2 gives detailed description for each pin.

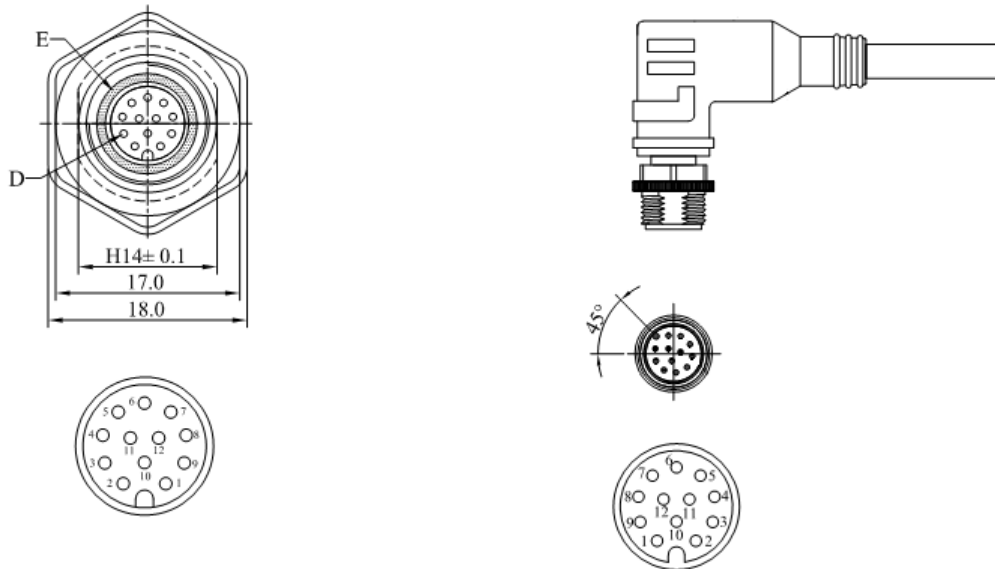

Picture 1. Radar Speed Sensor connectors

Table 2. Connector and cable pin-out

Pin No.	Wire Color	Pin Name	Pin Description
1	White	GND	This pin should be connected to the ground (negative) pole of the power supply.
2	Brown	+Vin	The power supply for the Radar Speed Sensor is provided on this pin. The Radar Speed Sensor power supply voltage must be in the range 9 VDC to 22 VDC, and the power supply must be able to provide at last 0,65W.
3	Green	RS232 – TxD	RS-232 data transmit signal.
4	Yellow	RS232 – RxD	RS-232 data receive signal.
5	Grey	GND	Signal ground.
6	Pink	CAN – H	CAN2.0B high signal.
7	Blue	CAN – L	CAN2.0B low signal.
8	Red	RS485 – D+	RS-485 data transmitter/receiver high signal.
9	Orange	RS485 – D-	RS-485 data transmitter/receiver low signal.
10	Purple	Alarm V+	Alarm – power supply +5V max. 100mA.
11	Black	Alarm1 SW	Alarm 1 - open collector switch signal max. 60mA
12	Violet	Alarm2 SW	Alarm 2 - open collector switch signal max. 60mA

4. Data Interface

Geolux Radar Speed Sensors offer multiple data interfaces, in order to make the system integration of the radar sensor device easy. In addition to RS-232 and RS-485 serial interfaces, Geolux Radar Speed Sensors also have a CAN interface, and additional Alarm GPIO pins.

4.1. Serial RS-232 interface

Serial RS-232 interface is used to send detected targets report as well as target detection statistics reports. Additionally, Radar Speed Sensor configuration is also performed through RS-232 interface.

Default communication parameters are:

Bitrates:	57600 bps
Data bits:	8
Stop bits:	1
Parity:	None

Two communication protocols are available, and more are possible upon the request. Simple ASCII-S protocol will report only the strongest target's speed and the more complex NMEA protocol will report multiple targets, counting and statistics. Detailed description of the communication protocols is given in the Chapter 5 of the User Manual.

4.2. Serial RS-485 interface

Serial RS-485 interface is used to send detected targets report as well as target detection statistics reports using the same data protocol that is used on RS-232 interface. This interface is also capable for radar sensor configuration. The RS-485 interface uses differential signals for communication so it is more convenient for the applications where distance from radar sensor to the controller that is collecting data from radar sensor is greater than 5m.

Default communication parameters are:

Bitrates:	57600 bps
Data bits:	8
Stop bits:	1
Parity:	None

Communication is done half-duplex over one twisted-pair communication line. The radar sensor is using communication line as master device – will send data to the communication line as targets are detected.

Same communication protocols that are available on the RS-232 interface are available on the RS-485 serial interface.

4.3. CAN interface

CAN interface is used to send events and statistics of all targets detected by the radar sensor. Interface is implementing standard CAN2.0B message oriented communication with 11-bit standard ID for each message. The ID for the messages can be configured in the configuration of the sensor. Sensors can be connected to the CAN bus with other equipment or if necessary more than one radar sensor with different ID can be connected to the single CAN bus. Default communication speed is 500kbps but this also can be changed in the configuration of the sensor.

4.4. Alarm signals

Alarm signals are used to indicate events to the collecting controller. That signals can be configured to indicate various events and states:

Table 3. Alarm signals events

No.	Event	Description
0	Inactive	Alarm signal is inactive
1	Target	Detected at least one valid target.
2	Approaching Target	Detected at least one valid approaching target.
3	Receding Target	Detected at least one valid receding target.
4	Speed – over limit	Detected at least one valid target with speed over the configured speed limit.
5	Speed – under limit	Speed of all detected targets is under the configured speed limit.
6	Approaching Speed – over limit	Detected at least one valid approaching target with speed over the configured speed limit.
7	Approaching Speed – under limit	Speed of all approaching detected targets is under the configured speed limit.
8	Receding Speed – over limit	Detected at least one valid receding target with speed over the configured speed limit.
9	Receding Speed – under limit	Speed of all receding detected targets is under the configured speed limit.

5. Data Protocols

Geolux GLX-RSS-2 speed sensors support two different communication protocols that send the detected target data from the radar sensor device. The user may select which data protocol will be used based on the system requirements. The ASCII-S protocol is very simple, as it only outputs the detected speed for a single target only. The more complex NMEA-like protocol outputs the detected speed and signal power for all detected targets, and the NMEA protocol also reports various statistics, such as detected target count, calculated road occupancy and average target speed.

Support for additional protocols is available upon customer request.

Geolux GLS-RSS-2 sensors also support a servicing protocol that allows the users to modify radar sensor device operating parameters.

5.1. ASCII-S protocol

The ASCII-S protocol has been designed with simple applications in mind. It is minimal and straightforward. ASCII-S protocol provides only the direction and speed information for the single strongest detected target. Radar device settings determine whether the radar detects only approaching targets, only receding targets, or both kind of targets. The radar sensor device periodically outputs the target data. The data output frequency depends on the current radar device setting, and can be either 20Hz, 10Hz, 2Hz or 1Hz. If there are no valid detected targets, no data will be sent from the radar device.

ASCII-S protocol periodically sends exactly 4 bytes of data plus additional `<0x0D>` ('\r') carriage-return character.

The first byte of data denotes the detected vehicle direction, and can be either a minus sign ('-'), a plus sign ('+') or a question mark sign ('?'). The minus sign denotes receding targets, the plus sign denotes approaching targets, and the question mark sign denotes non-directional targets.

The next three bytes of data indicate the speed of the detected vehicle. The speed is reported either in metric units (km/h) or in imperial units (mph), depending on the radar device settings. The speed reading is ASCII encoded.

The following line contains an example of the radar sensor output for an approaching target moving at 25 mph:

```
+025<0x0D>
```

The target with same speed but receding will have output:

```
-025<0x0D>
```

5.2. NMEA protocol

NMEA protocol is based on the standard protocol family widely used by the navigation equipment. NMEA protocol is sentence oriented, and is capable of sending multiple sentences with different information. The sentence content is designated by the starting keyword which is different for each sentence type. NMEA sentences are terminated with the checksum which makes this protocol extremely reliable.

While in NMEA mode, the radar sensor device outputs any of the following data sentences:

Detected target report

`$RDTGT,D1,S1,L1,D2,S2,L2,...,Dn,Sn,Ln*CSUM<CR><LF>`

<i>\$RDTGT:</i>	The keyword sent on the beginning of each detection report. This sentence is sent whenever there is detected at least one valid target.
<i>D1:</i>	The direction of the first (strongest) target (1 approaching, -1 receding).
<i>S1:</i>	The speed of the first detected target (speed ¹ is reported as speed*10).
<i>L1:</i>	The detected level of the signal reflection from the first target.
<i>D2:</i>	The direction of the second detected target (1 approaching, -1 receding).
<i>S2:</i>	The speed of the second detected target (speed is reported as Speed*10).
<i>L2:</i>	The detected level of the signal reflection from the second target.
...	
<i>Dn:</i>	The direction of the last detected target (1 approaching, -1 receding).
<i>Sn:</i>	The speed of the last detected target (speed is reported as Speed*10).
<i>Ln:</i>	The detected level of the signal reflection from the last target.
<i>CSUM:</i>	The check sum of the characters in the report from \$ to * excluding these characters.

Targets count report

`$RDCNT,D,S,L,aprCNT,rcdCNT*CSUM<CR><LF>`

<i>\$RDCNT:</i>	The keyword sent on the beginning of each counting report. The counting report is sent whenever new valid target is detected.
<i>D:</i>	The direction for the new counted target (1 approaching, -1 receding).
<i>S:</i>	The speed for the new counted target (speed is reported as Speed*10).
<i>L:</i>	The detection level for the new counter target.
<i>aprCNT:</i>	The cumulative counter for the approaching targets.
<i>rcdCNT:</i>	The cumulative counter for the receding targets.
<i>CSUM:</i>	The check sum of the characters in the report from \$ to * excluding these characters.

¹ In the radar sensor setting it is possible to select km/h or mph for the speed reporting

Target statistics report

`$RDSTA,count,avgSpeed,minSpeed,maxSpeed,roadOCP,tmpCNT*CSUM<CR><LF>`

\$RDSTA: The keyword sent on the beginning of each statistics report for approaching targets direction. The report is sent periodically and period is determined in the radar device settings. All values are relative to the time period from the last sent report.

count: The timeslot counter.

avgSpeed: The average speed for all approaching targets in the defined time period.

minSpeed: The minimal detected target speed for all approaching targets in the defined time period.

maxSpeed: The maximal detected target speed for all approaching targets in the defined time period.

roadOCP: The road occupation percentage for the defined time period calculated as number of samplings with at least one valid approaching detected target divided by the total number of samplings in the defined time period.

tmpCNT: The temporary counter of all approaching targets in the defined time period.

CSUM: The check sum of the characters in the report from \$ to * excluding these characters.

`$RDSTR,count,avgSpeed,minSpeed,maxSpeed,roadOCP,tmpCNT*CSUM<CR><LF>`

\$RDSTR: The keyword sent on the beginning of each statistics report for receding targets direction. The report is sent periodically and period is determined in the settings. All values are relative to the time period from the last sent report.

count: The timeslot counter.

avgSpeed: The average speed for all receding targets in the defined time period.

minSpeed: The minimal detected target speed for all receding targets in the defined time period.

maxSpeed: The maximal detected target speed for all receding targets in the defined time period.

roadOCP: The road occupation percentage for the defined time period calculated as number of samplings with at least one valid receding detected target divided by the total number of samplings in the defined time period.

tmpCNT: The temporary counter of all receding targets in the defined time period.

CSUM: The check sum of the characters in the report from \$ to * excluding these characters.

5.3. CAN protocol

CAN interface is using special protocol based on the standardized CAN message format. All messages are sent with standard 11-bit ID and all messages have same ID that is configured as radar sensor CAN ID in the settings. Protocol is message based and for each event separate message is sent. The first byte of the message data is always defining the type of the message content.

CAN protocol is defining the following data messages:

Detected target report

ID	SIZE	Data0	Data1	Data2	Data3	Data4	Data5	Data6	Data7
SensorID	5	0x01	D	S		L			

0x01: The keyword sent on the beginning of each message. This message is sent for every detected valid target.

D: The direction of the detected target (1 approaching, -1 receding).

S: The speed of the detected target (speed¹ is reported as speed*10).

L: The detected level of the signal reflection for the target (normalized to range from 1 to 255)

Targets count report

ID	SIZE	Data0	Data1	Data2	Data3	Data4	Data5	Data6	Data7
SensorID	8	0x02	D	S		counter			

0x02: The keyword sent on the beginning of each message. This message is sent for every new detected valid target.

D: The direction for the new counted target (1 approaching, -1 receding).

S: The speed for the new counted target (speed is reported as Speed*10).

counter: The cumulative counter for the approaching or receding targets, depending on the direction of the new detected target (if 1 this will be cumulative counter for approaching targets, if -1 this will be cumulative counter for receding targets)

Target statistics report – approaching

ID	SIZE	Data0	Data1	Data2	Data3	Data4	Data5	Data6	Data7
SensorID	8	0x03	count	avgS		minS		maxS	

0x03: The keyword sent on the beginning of each message. This message is sent periodically every 15s. The time period for accumulation is configured in the settings of the sensor.

count: The timeslot counter.

avgS: The average speed for all approaching targets in the defined time period.

- minS:* The minimal detected target speed for all approaching targets in the defined time period.
- maxS:* The maximal detected target speed for all approaching targets in the defined time period.

Target statistics report – receding

ID	SIZE	Data0	Data1	Data2	Data3	Data4	Data5	Data6	Data7
SensorID	8	0x04	count	avgS		minS		maxS	

- 0x04:* The keyword sent on the beginning of each message. This message is sent periodically every 15s. The time period for accumulation is configured in the settings of the sensor.
- count:* The timeslot counter.
- avgS:* The average speed for all receding targets in the defined time period.
- minS:* The minimal detected target speed for all receding targets in the defined time period.
- maxS:* The maximal detected target speed for all receding targets in the defined time period.

Road statistics report - occupation

ID	SIZE	Data0	Data1	Data2	Data3	Data4	Data5	Data6	Data7
SensorID	4	0x05	count	roadOCP-A	roadOCP-R				

- 0x05:* The keyword sent on the beginning of each message. This message is sent periodically every 15s. The time period for accumulation is configured in the settings of the sensor.
- count:* The timeslot counter.
- roadOCP-A:* The road occupation percentage for the time period in approaching direction (percentage of time when at least one target is detected)
- roadOCP-R:* The road occupation percentage for the time period in receding direction (percentage of time when at least one target is detected)

Road statistics report – counter approaching

ID	SIZE	Data0	Data1	Data2	Data3	Data4	Data5	Data6	Data7
SensorID	6	0x06	count	aprCounter					

- 0x06:* The keyword sent on the beginning of each message. This message is sent periodically every 15s. The time period for accumulation is configured in the settings of the sensor.
- count:* The timeslot counter.
- aprCounter:* Counter of the approaching targets for the current time period

Road statistics report – counter receding

ID	SIZE	Data0	Data1	Data2	Data3	Data4	Data5	Data6	Data7
SensorID	6	0x07	count	rcdCounter					

0x07: The keyword sent on the beginning of each message. This message is sent periodically every 15s. The time period for accumulation is configured in the settings of the sensor.

count: The timeslot counter.

rcdCounter: Counter of the receding targets for the current time period

5.4. Servicing protocol

The servicing protocol is used to retrieve and modify device operating parameters. Various device settings, such as unit system (imperial or metric), and the direction of detected vehicles (approaching or receding, or both) are configured using this protocol. Since all data protocols are on-way (both ASCII-S and NMEA protocol only output the data, they do not read incoming data), the servicing protocol is always active.

To make radar configuration easy, Geolux provides a Radar Configurator utility application. Regular users do not need to be concerned about the servicing protocol used between the Radar Configurator utility and the radar device. The Radar Configurator utility is described in the Chapter 8.

The servicing protocol listens on RS-232 serial port for incoming requests, and on each received request, it will answer back.

The following requests are recognized by the servicing protocol:

Change data protocol

```
#set_proto=nmea
#set_proto=ascii64
```

Sets the current data protocol. Default setting is ASCII-S (ascii64).

Change units type

```
#set_units=mph
#set_units=kmh
```

Sets the units type in which the target speed is reported. Default setting is imperial units (mph).

Change output data frequency

```
#set_out_freq=20
#set_out_freq=10
#set_out_freq=2
#set_out_freq=1
```

Changes the data output frequency; allowed values are 20Hz, 10Hz, 2Hz and 1Hz. Default setting is 20 Hz.

Change radar sensitivity

```
#set_sensitivity=0
#set_sensitivity=1
#set_sensitivity=2
#set_sensitivity=3
#set_sensitivity=4
#set_sensitivity=5
#set_sensitivity=6
#set_sensitivity=7
```

Changes the sensitivity of the radar sensor; allowed values are 0, 1, 2, 3, 4, 5, 6 and 7. Radar will be the most sensitive if setting is 7. Default setting is 7.

Change detected targets direction

```
#set_direction=in
#set_direction=out
#set_direction=both
```

Changes the parameter that specifies which vehicles will be detected. By default, only approaching vehicles are detected (in).

Change alarm 1 output setting

```
#set_alarm1=0
#set_alarm1=1
#set_alarm1=2
#set_alarm1=3
#set_alarm1=4
#set_alarm1=5
#set_alarm1=6
#set_alarm1=7
#set_alarm1=8
#set_alarm1=9
```

Changes the parameter that specifies behavior of alarm output signal.

Change alarm 2 output setting

```
#set_alarm2=0
#set_alarm2=1
#set_alarm2=2
#set_alarm2=3
#set_alarm2=4
#set_alarm2=5
#set_alarm2=6
```



```
#set_alarm2=7  
#set_alarm2=8  
#set_alarm2=9
```

Changes the parameter that specifies behavior of alarm output signal.

Change statistics accumulation period

```
#set_stats_period=15min  
#set_stats_period=30min  
#set_stats_period=1hr  
#set_stats_period=2hr  
#set_stats_period=6hr  
#set_stats_period=12hr  
#set_stats_period=24hr
```

Changes the time period for collecting target statistics. The collected target statistics are reported on NMEA protocol using \$RDSTA and \$RDSTR sentences.

Retrieve current device status

```
#get_info
```

Requests the current device status. Here is an example status output:

```
# firmware:2.1.0  
# pga_gain:2  
# proto:nmea  
# units:mph  
# out_freq:20  
# sensitivity:7  
# direction:in  
# stats_period:30min
```

6. Radar Configurator Utility

Geolux provides a user-friendly PC application for configuring the Radar Sensor operating parameters. Additionally, the Radar Configurator Utility displays all currently detected targets and detected target statistics.

When started, the Configurator Utility displays its main window. Initially, no target data is displayed, as the connection to the radar device is not established.

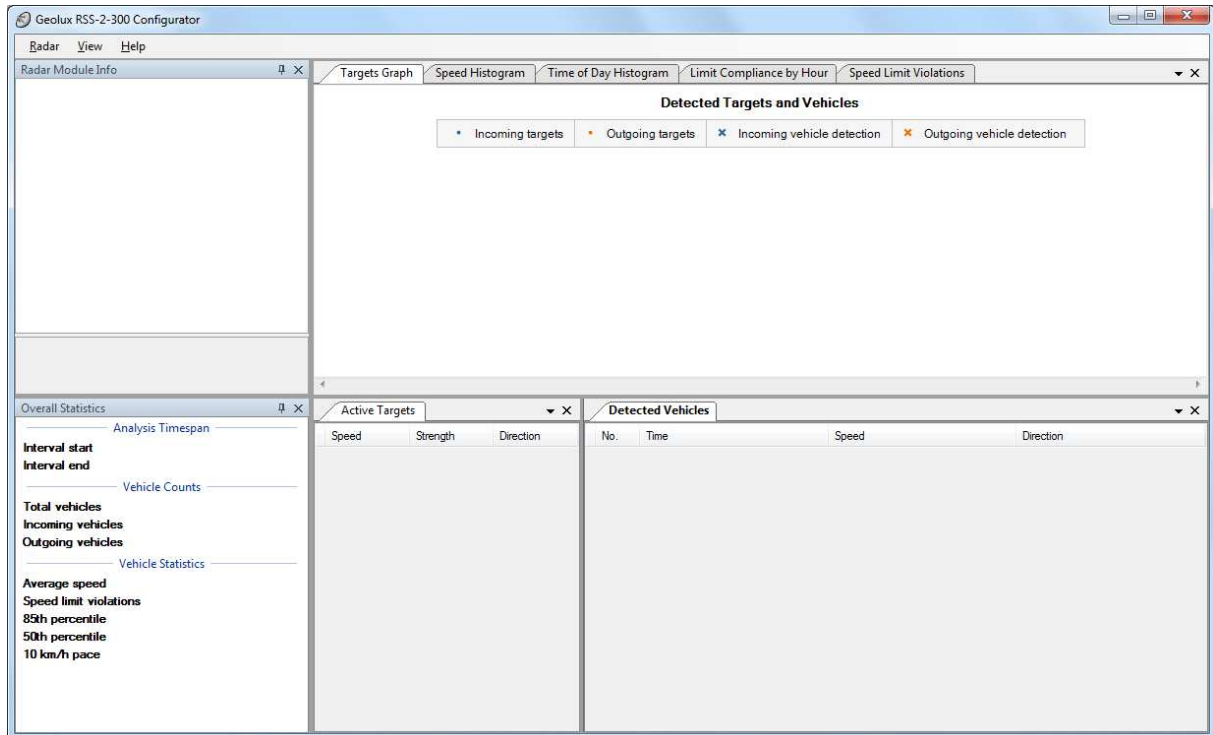

Picture 2. Radar Configurator main window

To connect the Radar Configurator utility with the speed radar device, connect your PC to the speed radar using an RS-232 serial cable connection. Then, select the *Radar* → *Connect* menu option in the Radar Configurator Utility, and choose the appropriate COM port number. The Radar Configurator will try to establish a data link between your PC and the radar sensor device. After the data link is established, active Radar Module parameters will be displayed:

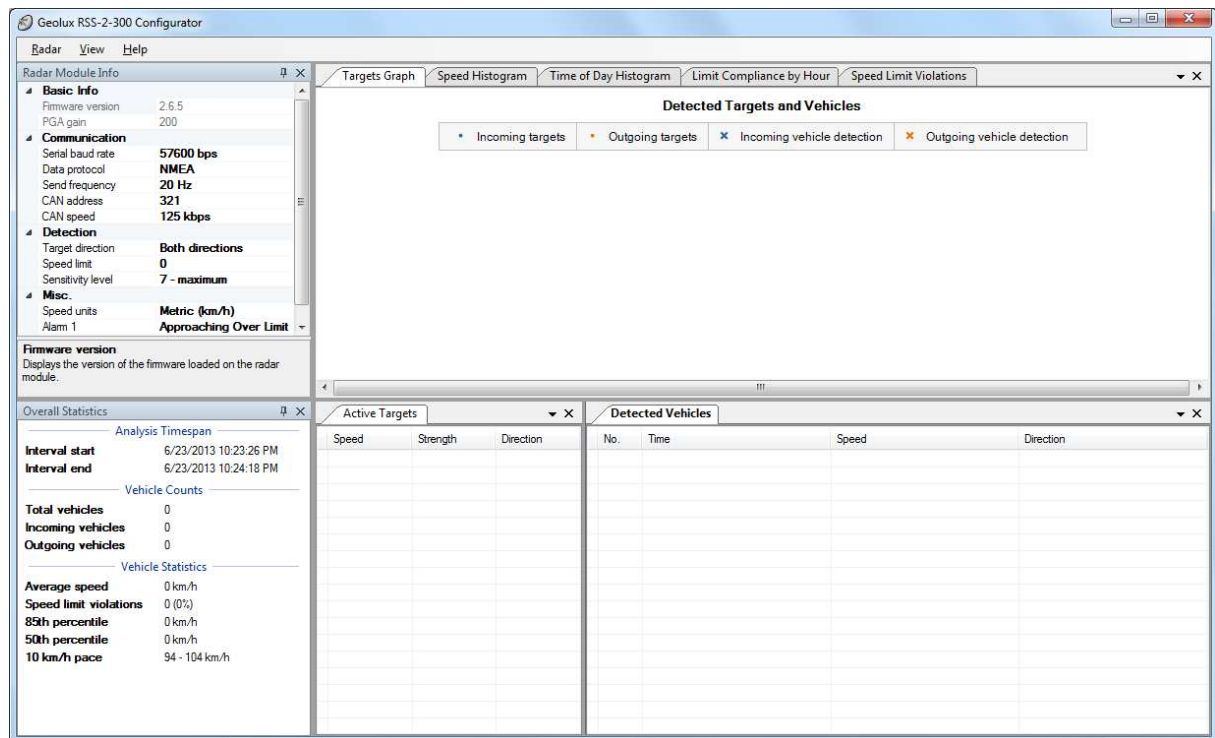

Picture 3. Radar Configurator main window with device connected

The utility window is divided into several panes, that can be manually re-arranged. The first panel (at the top-left corner) is the Radar Module Info pane that displays the radar module information and operating parameters. Some of these parameters can be changed by editing the values directly inside the Radar Module Info pane. The following information is displayed:

<i>Firmware version</i>	the version of the firmware running in the radar sensor device
<i>PGA gain</i>	the current gain value of the analog radar signal amplifier; the gain is automatically adjusted to provide maximum possible dynamic range
<i>Serial baud rate</i>	the communication bitrate used for serial communication with the radar device
<i>Data protocol</i>	the data protocol used over serial link; several protocols are available, NMEA protocol provides most versatile information from the radar sensor
<i>Send frequency</i>	the frequency at which the data is sent from the sensor through communication links, typically it is 20 times per second
<i>CAN address</i>	the CAN device address used when sending the data through CAN communication link, value can be between 1 and 2047
<i>CAN speed</i>	the bitrate used for the CAN bus communication
<i>Target direction</i>	select whether all targets are reported, or only incoming or outgoing targets are reported
<i>Speed limit</i>	the road speed limit value; this value is used to generate the alarms, and for vehicle statistics graphs
<i>Sensitivity level</i>	radar sensor sensitivity – maximum level provides furthest detection range, decreasing this level decreases the detection range

<i>Speed units</i>	select if the speed is reported in metric (km/h) or imperial (mph) units
<i>Alarm 1</i>	configure alarm 1 output
<i>Alarm 2</i>	configure alarm 2 output

The alarm lines can be programmed to be active under following conditions:

<i>Inactive</i>	the alarm line is not active
<i>Valid target</i>	active when there is a any moving target detected
<i>Approaching target</i>	active when an approaching target is detected
<i>Receding target</i>	active when a receding target is detected
<i>Speed over limit</i>	active when there is a vehicle driving faster than the speed limit
<i>Speed under limit</i>	active when there is a vehicle driving slower than the speed limit
<i>Approaching over limit</i>	active when there is an approaching vehicle driving faster than the speed limit
<i>Approaching under limit</i>	active when there is an approaching vehicle driving slower than the speed limit
<i>Receding over limit</i>	active when there is a receding vehicle driving faster than the speed limit
<i>Receding under limit</i>	active when there is a receding vehicle driving slower than the speed limit
<i>Freq. Output</i>	when a vehicle is detected, outputs a square wave, 100 impulses per meter (ipm); if the speed is given in km/h the frequency can be calculated by the following formula: $f_{[Hz]} = v_{\frac{km}{h}} * \frac{100}{3.6}$
<i>Approaching Freq.</i>	frequency output, but only for approaching vehicles
<i>Receding Freq.</i>	frequency output, but only for receding vehicles

The second pane (in the lower-left corner) is the Overall Statistics pane, which displays statistics for all detected targets (the statistics data is reset every time when the application re-connects to the speed sensor). The following information is displayed:

<i>Interval start</i>	the date and time of data analysis start (the time when the connection to the radar device was established)
<i>Interval end</i>	the date and time of data analysis end (the current time, constantly updated)
<i>Total vehicles</i>	the total number of detected vehicles
<i>Incoming vehicles</i>	the number of all approaching vehicles detected
<i>Outgoing vehicles</i>	the number of all receding vehicles detected
<i>Average speed</i>	the average speed for all vehicles
<i>Speed limit violations</i>	the total number and percentage of speed limit violations
<i>85th percentile</i>	the 85 th speed percentile (the speed value calculated so that 85% of all detected vehicles were driving below this speed value)
<i>50th percentile</i>	the 50 th speed percentile (the speed value calculated so that 50% of all detected vehicles were driving below this speed value)
<i>10 km/h pace</i>	the 10 km/h speed interval where the speed of most detected vehicles falls into

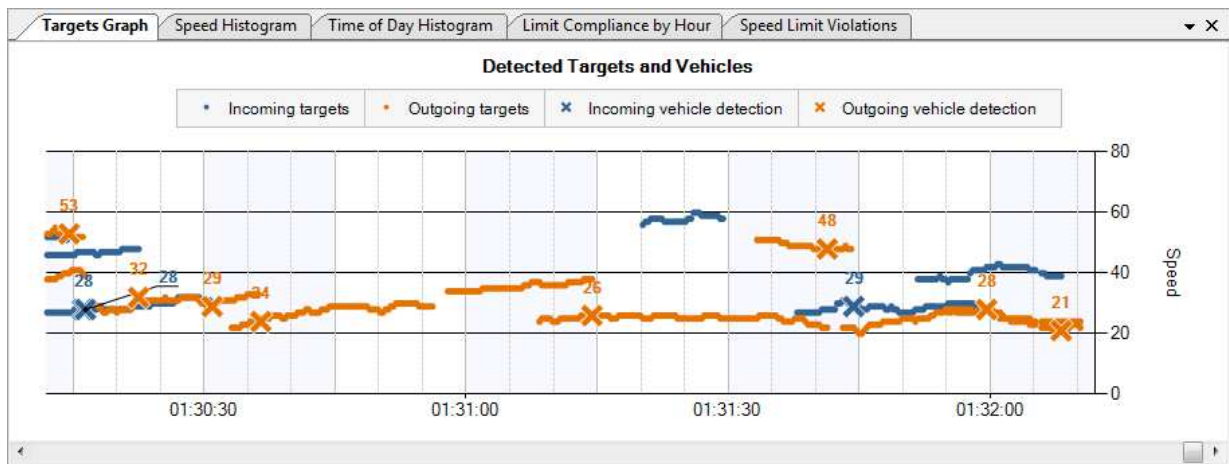

Picture 4. Graphs and charts pane



The third pane (the large pane in the top-right corner) displays various graphs and charts:

<i>Targets Graph</i>	the targets graph plots the active targets on the timeline; it also marks target counts (vehicle detection) with an X symbol, and is useful to track the active vehicle information
<i>Speed Histogram</i>	displays the speed histogram information (the number of vehicles per speed range)
<i>Time of Day Hist.</i>	displays the time of day histogram (the number of vehicles per hour of day)
<i>Limit Compliance by Hour</i>	for each hour in day, displays the number of vehicles driving above/below the speed limit
<i>Speed Limit Violations</i>	displays the pie chart representing the percentage of vehicles driving below/above the speed limit

The lower part of the application window contains two panes. The Active Targets pane simply lists all currently detected targets, and the Detected Vehicles pane contains the list of all detected vehicles, complete with the time of detection, vehicle direction and the vehicle speed.



7. Appendix A – EN Test Report Summary

Test performed by: *SIQ – Slovenian Institute of Quality and Metrology*
 Test report No.: *T251-0760/11*
 Date: *2011-09-22*
 Standards: *EN 50293:2000*
 EN 61000-6-2:2005
 EN 61000-6-4:2007
 EN 61000-3-2:2006+A1:2009+A2:2009
 EN 61000-3-3:2008

 Slovenski inštitut za kakovost in meroslovje Slovenian Institute of Quality and Metrology																							
<h1>Poročilo o preskusu / Test Report</h1>																							
Št. / No.: T251-0760/11																							
Datum / Date: 2011-09-22																							
<table border="1"> <tr> <th>Proizvod / Product</th> </tr> <tr> <td>Radar Speed Sensor Type: GLX-RSS-2-300</td> </tr> <tr> <th>Naročnik / Applicant</th> </tr> <tr> <td>Geolux d.o.o. Ljudevita Gaja 62, 10430 Samobor, Croatia</td> </tr> <tr> <th>Proizvajalec / Manufacturer</th> </tr> <tr> <td>Geolux d.o.o. Ljudevita Gaja 62, 10430 Samobor, Croatia</td> </tr> <tr> <th>Blagovna znamka / Trade Mark</th> </tr> <tr> <td>/</td> </tr> <tr> <th>Standardi – predpisi / Standards - regulations</th> </tr> <tr> <td>EN 50293:2000; EN 61000-6-2:2005; EN 61000-6-4:2007; EN 61000-3-2:2006+A1:2009+A2:2009; EN 61000-3-3:2008</td> </tr> </table>	Proizvod / Product	Radar Speed Sensor Type: GLX-RSS-2-300	Naročnik / Applicant	Geolux d.o.o. Ljudevita Gaja 62, 10430 Samobor, Croatia	Proizvajalec / Manufacturer	Geolux d.o.o. Ljudevita Gaja 62, 10430 Samobor, Croatia	Blagovna znamka / Trade Mark	/	Standardi – predpisi / Standards - regulations	EN 50293:2000; EN 61000-6-2:2005; EN 61000-6-4:2007; EN 61000-3-2:2006+A1:2009+A2:2009; EN 61000-3-3:2008	<table border="1"> <tr> <th>Listov / Pages</th> </tr> <tr> <td>35</td> </tr> <tr> <th>Vrsta preskusa / Test procedure</th> </tr> <tr> <td>EMC</td> </tr> <tr> <th>Št. merjencev / No. of items tested</th> </tr> <tr> <td>1</td> </tr> <tr> <th>Mapa predmeta št. / Subject file No.</th> </tr> <tr> <td>C20111383</td> </tr> <tr> <th>Kraj preskusa / Place of test</th> </tr> <tr> <td>SIQ, EMC lab., Trpinčeva ul.39, 1000 Ljubljana, SLOVENIA</td> </tr> <tr> <th>Opomba / Remark</th> </tr> <tr> <td>/</td> </tr> </table>	Listov / Pages	35	Vrsta preskusa / Test procedure	EMC	Št. merjencev / No. of items tested	1	Mapa predmeta št. / Subject file No.	C20111383	Kraj preskusa / Place of test	SIQ, EMC lab., Trpinčeva ul.39, 1000 Ljubljana, SLOVENIA	Opomba / Remark	/
Proizvod / Product																							
Radar Speed Sensor Type: GLX-RSS-2-300																							
Naročnik / Applicant																							
Geolux d.o.o. Ljudevita Gaja 62, 10430 Samobor, Croatia																							
Proizvajalec / Manufacturer																							
Geolux d.o.o. Ljudevita Gaja 62, 10430 Samobor, Croatia																							
Blagovna znamka / Trade Mark																							
/																							
Standardi – predpisi / Standards - regulations																							
EN 50293:2000; EN 61000-6-2:2005; EN 61000-6-4:2007; EN 61000-3-2:2006+A1:2009+A2:2009; EN 61000-3-3:2008																							
Listov / Pages																							
35																							
Vrsta preskusa / Test procedure																							
EMC																							
Št. merjencev / No. of items tested																							
1																							
Mapa predmeta št. / Subject file No.																							
C20111383																							
Kraj preskusa / Place of test																							
SIQ, EMC lab., Trpinčeva ul.39, 1000 Ljubljana, SLOVENIA																							
Opomba / Remark																							
/																							
<table border="1"> <tr> <th>Zaključek / Conclusion</th> </tr> <tr> <td> Preskušani proizvod ustreza zahtevam navedenih standardov. / Tested product complies with the requirements of stated standards. Rezultati preskusov se nanašajo samo na preskušani vzorec. / The test results relate only to the item tested. Datum prispelja vzorca / Date of receipt of test item: 2011-08-04 Datum izvedbe preskusov / Date of performance of tests: 2011-08-12 - 2011-09-12 </td> </tr> </table>		Zaključek / Conclusion	Preskušani proizvod ustreza zahtevam navedenih standardov. / Tested product complies with the requirements of stated standards. Rezultati preskusov se nanašajo samo na preskušani vzorec. / The test results relate only to the item tested. Datum prispelja vzorca / Date of receipt of test item: 2011-08-04 Datum izvedbe preskusov / Date of performance of tests: 2011-08-12 - 2011-09-12																				
Zaključek / Conclusion																							
Preskušani proizvod ustreza zahtevam navedenih standardov. / Tested product complies with the requirements of stated standards. Rezultati preskusov se nanašajo samo na preskušani vzorec. / The test results relate only to the item tested. Datum prispelja vzorca / Date of receipt of test item: 2011-08-04 Datum izvedbe preskusov / Date of performance of tests: 2011-08-12 - 2011-09-12																							
Testni laboratorij je akreditiran pri Slovenski Akreditaciji, Reg. Št.LP-009 / Testing laboratory is accredited by Slovenian Accreditation, Reg. No.LP-009																							
Odgovoren za preskušanje / Responsible for the test  Gregor Šterk	Vodja področja / Department Manager  Marjan Mak																						
Slovenski inštitut za kakovost in meroslovje • Slovenian Institute of Quality and Metrology Tržaška cesta 2, SI-1000 Ljubljana, Slovenija • t: +386 01 4778 160 • f: +386 01 4778 444 • e: info@siq.si • http://www.siq.si Razmnoževanje poročila, razen v celoti, ni dovoljeno / This report shall not be reproduced except in full																							
TN4005 izdaja/issue: 02/2011-08																							

8. Appendix B – FCC Test Report Summary

Test performed by: *SIQ – Slovenian Institute of Quality and Metrology*
 Test report No.: *T251-0864/11*
 Date: *2011-09-22*
 Standards: *FCC Part 15, Subpart C*

 Slovenski inštitut za kakovost in meroslovje Slovenian Institute of Quality and Metrology	
<h1>Poročilo o preskusu / Test Report</h1>	
Št. / No.: T251-0864/11	
Datum / Date: 2011-09-22	
Proizvod / Product Radar Speed Sensor Type: GLX-RSS-2-300	Lista / Pages 35
Naročnik / Applicant Geolux d.o.o. Ljudevita Gaja 62, 10430 Samobor, Croatia	Vrsta preskusa / Test procedure EMC
Proizvajalec / Manufacturer Geolux d.o.o. Ljudevita Gaja 62, 10430 Samobor, Croatia	Št. merjencev / No. of items tested 1
Blagovna znamka / Trade Mark /	Mapa predmeta št. / Subject file No. C20111383
Standardi – predpisi / Standards - regulations FCC Part 15, Subpart C	Kraj preskusa / Place of test SIQ, EMC lab., Trpinčeva ul.39, 1000 Ljubljana, SLOVENIA
Opomba / Remark /	
Zaključek / Conclusion Preskušani proizvod ustreza zahtevam navedenih standardov. / Tested product complies with the requirements of stated standards. Rezultati preskusov se nanašajo samo na preskušani vzorec. / The test results relate only to the item tested. Datum prispelja vzorca / Date of receipt of test item: 2011-09-04 Datum izvedbe preskusov / Date of performance of tests: 2011-09-12 - 2011-09-09	
<small>Testni laboratorij je akreditiran pri Slovenski Akreditaciji, Reg. št. LP-009 / Testing laboratory is accredited by Slovenian Accreditation, Reg. No. LP-009</small>	
Odgovoren za preskušanje / Responsible for the test  Gregor Šterk	Vodja področja / Department Manager  Marjan Mak
<small>Slovenski inštitut za kakovost in meroslovje • Slovenian Institute of Quality and Metrology Tržaška cesta 2, SI-1000 Ljubljana, Slovenia • t: +386 01 4778 100 • f: +386 01 4778 444 • e: info@siq.si • http://www.siq.si Razmnoževanje poročila, razen v celoti, ni dovoljeno / This report shall not be reproduced except in full</small>	
<small>TN4005 Izdaja/Issue: 02/2011-05</small>	

9. Appendix C – Mechanical Assembly

